

# Generalized Net Model of the Building a Website

**Krasen Dimitrov and Veselina Bureva**

Intelligent Systems Laboratory, “Prof. Dr. Assen Zlatarov” University,  
 “Prof. Yakimov” Blvd, Burgas–8010, Bulgaria  
 e-mails: kdimitrov1995@gmail.com, vbureva@btu.bg

**Abstract:** The proposed Generalized net model describes the process of website construction. It includes the preferences of the clients according to the website design and functionalities. The ability of website problems detection is considered. The presented generalized net can be used for analyzing and monitoring the website development process.

**Keywords:** Generalized Nets, Website.

**AMS Classification:** 68Q85, 68M11.

## 1 Introduction

The theory of generalized nets is presented in [4, 6, 7]. During the years a lot of publications extending its aspects are written [9]. In the generalized net theory, the conditions of the process are visualized by transitions which are shown in the Figure 1.

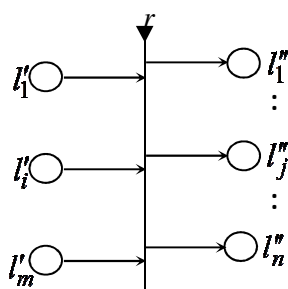

Figure 1. A GN-transition

A transition may contain  $m$  input places and  $n$  output places where  $m, n \geq 1$ . The formal description of the transition is given:

$$Z = \langle L', L'', t_1, t_2, r, M, \square \rangle,$$

where:  $L'$  and  $L''$  are the sets containing finite, non-empty places. These places represent transition's inputs and outputs.  $t_1$  is the current time-moment when the transition is firing.  $t_2$  is the current value of the duration of the active state of the transition.  $r$  is an index matrix representing

the condition of the transition to determine which tokens will transfer from the input places to the output places;  $M$  is an index matrix of the capacities of transition's arcs.  $\square$  is an object having a form similar to a Boolean expression. It determines how the places will enter in the transition: together or separately [4, 6, 7].

## 2 Generalized Net Model of the Process of Building a Website

The applications of generalized nets can be found in the area of data mining, pattern recognition, neural networks, genetic algorithms, databases, OLAP [1–3, 8]. In the current research work a generalized net model of the building a website process is constructed (Figure 2). It contains the following set of transitions:

$$A = \{Z_1, Z_2, Z_3, Z_4, Z_5, Z_6, Z_7, Z_8, Z_9, Z_{10}\},$$

where:

- $Z_1$  - “entering clients with website orders”;
- $Z_2$  - “suggesting of possible designs”;
- $Z_3$  - “entering DB with employees”;
- $Z_4$  - “the client provides content and functionality requirements of the website”;
- $Z_5$  - “discussing the design of the website”;
- $Z_6$  - “approving the design”;
- $Z_7$  - “programming of the website”;
- $Z_8$  - “testing the website”;
- $Z_9$  - “starting the website”;
- $Z_{10}$  - “providing maintenance of the website”.

Initially in the GN there are three tokens in places  $L_5$ ,  $L_8$  and  $L_{16}$  with the following characteristics:

“DB with website orders from clients” in place  $L_5$ ,  
“DB with possible designs” in place  $L_8$ ,  
“DB with employees” in place  $L_{16}$ .

These tokens will be in their own places during all the time of GN functioning. They are generating new tokens at certain time moments which entering in places  $L_2, L_3, L_4, L_7, L_{10}, L_{11}, L_{12}, L_{13}, L_{14}, L_{15}$ .

Token enters the net via place  $L_1$  with initial characteristic: “new client with website order”. Transition  $Z_1$  has the following form:

$$Z_1 = \langle \{L_1, L_5\}, \{L_2, L_3, L_4, L_5\}, R_1, \vee(L_1, L_5) \rangle,$$

where

$$R_1 = \begin{array}{c|cccc} & L_2 & L_3 & L_4 & L_5 \\ \hline L_1 & false & false & false & true \\ L_5 & W_{5,2} & W_{5,3} & W_{5,4} & W_{5,5} \end{array}$$

and

$W_{5,2} = W_{5,3} = W_{5,4}$  - “there is selected client with a website order”;

$W_{5,5} = (W_{5,2} \wedge W_{5,3} \wedge W_{5,4})$ .

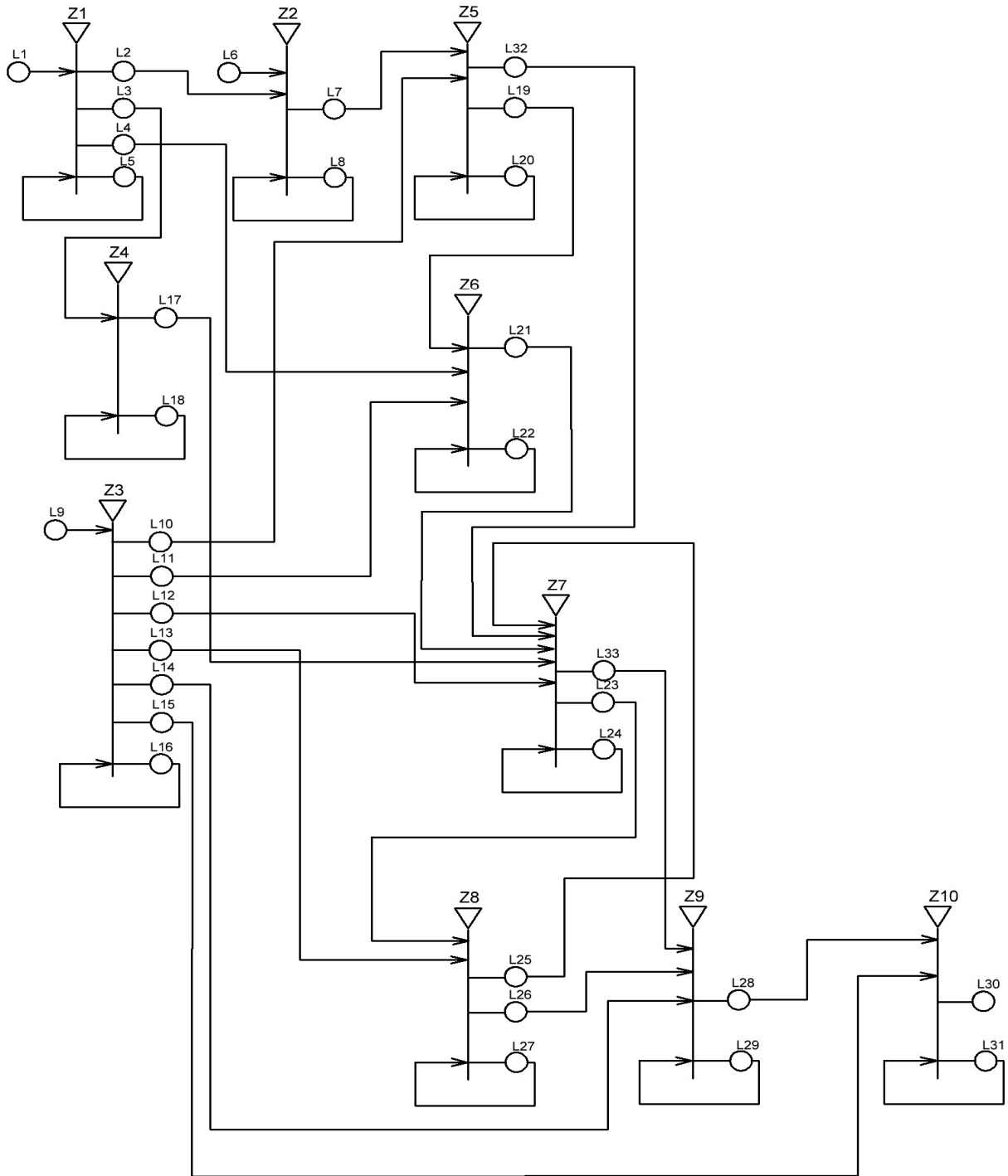

Figure 2. Generalized net model of “building a website”

The tokens entering in place  $L_5$  do not receive new characteristics. The tokens from place  $L_5$  generate three new tokens, which enter in places  $L_2$ ,  $L_3$ ,  $L_4$  with the following characteristics:

- “chosen design by client” in place  $L_2$ ,
- “information for the content and functionality of the website” in place  $L_3$ ,
- “approved design” in place  $L_4$ .

Token enters the net via place  $L_6$  with initial characteristic: “new possible design”. Transition  $Z_2$  has the following form:

$$Z_2 = \langle \{L_2, L_6, L_8\}, \{L_7, L_8\}, R_2, \vee(L_2, L_6, L_8) \rangle$$

where

$$R_2 = \begin{array}{c|cc} & L_7 & L_8 \\ \hline L_6 & false & true \\ L_2 & false & true \\ L_8 & W_{8,7} & W_{8,8} \end{array}$$

and

$W_{8,7}$  = “there is selected design by client”;

$W_{8,8} = \neg W_{8,7}$ .

The tokens entering in place  $L_8$  do not receive new characteristics. The tokens from place  $L_8$  generate one new token, which enters in place  $L_7$  with the following characteristic:

“*selected design by client*”.

Token enters the net via place  $L_9$  with initial characteristic: “*new employee*”.

Transition  $Z_3$  has the following form:

$$Z_3 = \langle \{L_9, L_{16}\}, \{L_{10}, L_{11}, L_{12}, L_{13}, L_{14}, L_{15}, L_{16}\}, R_3, \vee(L_9, L_{16}) \rangle$$

where

$$R_3 = \begin{array}{c|ccccccc} & L_{10} & L_{11} & L_{12} & L_{13} & L_{14} & L_{15} & L_{16} \\ \hline L_9 & false & false & false & false & false & false & true \\ L_{16} & W_{16,10} & W_{16,11} & W_{16,12} & W_{16,13} & W_{16,14} & W_{16,15} & W_{16,16} \end{array}$$

and

$W_{16,10} = W_{16,12} = W_{16,13} = W_{16,14}$  - “there is a selected employee for work on the website”;

$W_{16,11}$  = “there is a selected employee for approval of the website”;

$W_{16,15}$  = “there is a selected employee for maintenance of the website”;

$W_{16,16} = \neg (W_{16,10} \wedge W_{16,11} \wedge W_{16,12} \wedge W_{16,13} \wedge W_{16,14} \wedge W_{16,15})$ .

The tokens entering in place  $L_{16}$  do not receive new characteristics. The token from place  $L_{16}$  generate new tokens, which enter in places  $L_{10}$ ,  $L_{11}$ ,  $L_{12}$ ,  $L_{13}$ ,  $L_{14}$  and  $L_{15}$  with the following characteristics:

“*selected employee for work on the website*” in place  $L_{10}$ ,

“*selected employee for approval of the design*” in place  $L_{11}$ ,

“*selected employee for programming of the website*” in place  $L_{12}$ ,

“*selected employee for testing of the website*” in place  $L_{13}$ ,

“*selected employee for starting the website*” in place  $L_{14}$ ,

“*selected employee for maintenance of the website*” in place  $L_{15}$ .

Transition  $Z_4$  has the following from:

$$Z_4 = \langle \{L_3, L_{17}, L_{18}\}, \{L_{17}, L_{18}\}, R_4, \vee(L_3, L_{17}, L_{18}) \rangle$$

where

$$R_4 = \begin{array}{c|cc} & L_{17} & L_{18} \\ \hline L_3 & false & true \\ L_{17} & false & true \\ L_{18} & W_{18,17} & W_{18,18} \end{array}$$

and

$W_{18,17} = \text{“there are client requirements for the content and functionality of the website”};$

$W_{18,18} = \neg W_{18,17}.$

The tokens entering in place  $L_{18}$  do not receive new characteristics. The tokens from place  $L_{18}$  generates new token, which enters in place  $L_{17}$  with the following characteristic:

*“Requirements for the content and functionality of the website”.*

Transition  $Z_5$  has the following form:

$$Z_5 = \langle \{L_7, L_{10}, L_{20}\}, \{L_{19}, L_{20}, L_{32}\}, R_5, \vee(L_7, L_{10}, L_{20}) \rangle$$

where

$$R_5 = \begin{array}{c|ccc} & L_{19} & L_{20} & L_{32} \\ \hline L_7 & false & true & false \\ L_{10} & false & true & false \\ L_{20} & W_{20,19} & W_{20,20} & W_{20,32} \end{array}$$

$W_{20,19} = \text{“there is a completed design”};$

$W_{20,32} = \text{“the design doesn't need approval”};$

$W_{20,20} = \neg (W_{20,19} \wedge W_{20,32}).$

The tokens entering in place  $L_{20}$  do not receive new characteristics. The tokens from place  $L_{20}$  generate two new tokens, which enter in places  $L_{19}$  and  $L_{32}$  with the following characteristics:

*“completed design for approval”* in place  $L_{19}$  and  
*“completed design without need of approval”* in place  $L_{32}$ .

Transition  $Z_6$  has the following form:

$$Z_6 = \langle \{L_4, L_{11}, L_{16}, L_{22}\}, \{L_{21}, L_{22}\}, R_6, \vee(L_4, L_{11}, L_{16}, L_{22}) \rangle$$

where

$$R_6 = \begin{array}{c|cc} & L_{21} & L_{22} \\ \hline L_4 & false & true \\ L_{11} & false & true \\ L_{16} & false & true \\ L_{22} & W_{22,21} & W_{22,22} \end{array}$$

and

$W_{22,21} = \text{“there is an approved design”};$

$W_{22,22} = \neg W_{22,21}.$

The tokens entering in place  $L_{22}$  do not receive new characteristics. The token from place  $L_{22}$  generate one new token, which enters in place  $L_{21}$  with the following characteristic:

*“approved design”.*

Transition  $Z_7$  has the following form:

$$Z_7 = \langle \{L_{12}, L_{17}, L_{21}, L_{25}, L_{30}, L_{24}, L_{32}\}, \{L_{23}, L_{24}, L_{33}\}, R_7, \vee(L_{12}, L_{17}, L_{21}, L_{25}, L_{30}, L_{24}, L_{32}) \rangle$$

where

$R_7 =$	$L_{23}$	$L_{33}$	$L_{24}$
$L_{12}$	<i>false</i>	<i>false</i>	<i>true</i>
$L_{17}$	<i>false</i>	<i>false</i>	<i>true</i>
$L_{21}$	<i>false</i>	<i>false</i>	<i>true</i>
$L_{25}$	<i>false</i>	<i>false</i>	<i>true</i>
$L_{30}$	<i>false</i>	<i>false</i>	<i>true</i>
$L_{32}$	<i>false</i>	<i>false</i>	<i>true</i>
$L_{24}$	$W_{24,23}$	$W_{24,33}$	$W_{24,24}$

and

$W_{24,23}$  = “there is a website programmed”;

$W_{24,33}$  = “there is not necessity of testing”;

$W_{24,24} = \neg (W_{24,23} \wedge W_{24,33})$ .

The tokens entering in place  $L_{24}$  do not receive new characteristics. The token from place  $L_{24}$  generates two new tokens, which enter in place  $L_{23}$  and  $L_{33}$  with the following characteristics:

“*website programmed*” in place  $L_{21}$ ,

“*website without testing*” in place  $L_{33}$ .

Transition  $Z_8$  has the following form:

$$Z_8 = \langle \{L_{13}, L_{23}, L_{27}\}, \{L_{25}, L_{26}, L_{27}\}, R_8, \vee(L_{13}, L_{23}, L_{27}) \rangle$$

where

$R_8 =$	$L_{25}$	$L_{26}$	$L_{27}$
$L_{13}$	<i>false</i>	<i>true</i>	<i>false</i>
$L_{23}$	<i>false</i>	<i>true</i>	<i>false</i>
$L_{27}$	$W_{27,25}$	$W_{27,26}$	$W_{27,27}$

and

$W_{27,25}$  = “there is a problem in the website”;

$W_{27,26}$  = “there is a website tested”;

$W_{27,27} = \neg (W_{27,25} \wedge W_{27,26})$ .

The tokens entering in place  $L_{27}$  do not receive new characteristics. The token from place  $L_{27}$  generates two new tokens, which enter in place  $L_{25}$  and  $L_{26}$  with the following characteristics:

“*website with problem*” in place  $L_{25}$ ,

“*website tested*” in place  $L_{26}$ .

Transition  $Z_9$  has the following form:

$$Z_9 = \langle \{L_{14}, L_{26}, L_{29}, L_{33}\}, \{L_{28}, L_{29}\}, R_9, \vee(L_{14}, L_{26}, L_{29}, L_{33}) \rangle$$

where

$R_9 =$	$L_{28}$	$L_{29}$
$L_{14}$	<i>false</i>	<i>true</i>
$L_{26}$	<i>false</i>	<i>true</i>
$L_{33}$	<i>false</i>	<i>true</i>
$L_{29}$	$W_{29,28}$	$W_{29,29}$

and

$W_{29,28} = \text{“there is a website launched”}$ ;

$W_{29,29} = \neg W_{29,28}$ .

The tokens entering in place  $L_{29}$  do not receive new characteristics. The token from place  $L_{29}$  generates new token, which enters in place  $L_{28}$  with the following characteristic:

*“website launched”*.

Transition  $Z_{10}$  has the following form:

$$Z_{10} = \langle \{L_{15}, L_{28}, L_{31}\}, \{L_{30}, L_{31}\}, R_{10}, \vee(L_{15}, L_{28}, L_{31}) \rangle$$

where

$$R_{10} = \begin{array}{c|cc} & L_{30} & L_{31} \\ \hline L_{15} & false & true \\ L_{28} & false & true \\ L_{31} & W_{31,30} & W_{31,31} \end{array}$$

and

$W_{31,30} = \text{“there is a problem encountered during maintenance”}$ ;

$W_{31,31} = \neg W_{31,30}$ .

The tokens entering in place  $L_{31}$  do not receive new characteristics. The token from place  $L_{31}$  generates new token, which enters in place  $L_{30}$  with the following characteristic:

*“website with a problem encountered during maintenance”*

### 3 Conclusion

The constructed generalized net model describes the process of “building a website”. It has the ability to skip the step of approving the website design. It presents testing step for correcting occurred errors. The generalized net model can be used for monitoring and optimizing the process of website development.

### References

- [1] Atanassov K., Generalized Nets as a Tool for the Modelling of Data Mining Processes, *Innovative Issues in Intelligent Systems*, Vol. 623 of the series Studies in Computational Intelligence, 2016, 161-215.
- [2] Atanassov K., O. Roeva, T. Pencheva, A. Shannon, *Generalized Nets in Artificial Intelligence. Volume 7: Generalized Nets and Genetic Algorithms*, Prof. M. Drinov Academic Publishing House, Sofia, 2013.
- [3] Atanassov K., S. Sotirov, *Generalized Nets in Artificial Intelligence, Volume 6: Generalized Nets and Supervised Neural Networks*, Prof. M. Drinov Academic Publishing House, Sofia, 2012.
- [4] Atanassov, K., E. Sotirova, *Generalized Nets*, Professor Marin Drinov Academic Publishing House, 2017 (in Bulgarian).

- [5] Atanassov, K., G. Gluhchev, S. Hadjitodorov, A. Shannon, V. Vassilev, *Generalized Nets and Pattern Recognition*, KvB Visual Concepts Pty Ltd, Monograph No. 6, Sydney, 2003.
- [6] Atanassov, K., *Generalized Nets*, World Scientific, Singapore, 1991.
- [7] Atanassov, K., *On Generalized Nets Theory*, Prof. M. Drinov Academic Publishing House, Sofia, 2007.
- [8] Kolev, B., E. El-Darzi, E. Sotirova, K. Atanassov, P. Chountas, V. Kodogiannis, *Generalized Nets in Artificial Intelligence. Volume 3: Generalized Nets, Relation Databases and Expert Systems*, Prof. M. Drinov Academic Publishing House, Sofia, 2006.
- [9] Zoteva, D., M. Krawczak, Generalized Nets as a Tool for the Modelling of Data Mining Processes. A Survey, *Issues in Intuitionistic Fuzzy Sets and Generalized Nets*, Vol. 13, 2017, 1–60